

MSR Series



MSR400

MSR400 Rear Panel



MSR250

MSR250 Rear Panel



All-in-one sound solutions that are powerful, versatile, and reliable.

MSR400

- Bi-amplified 12-inch cone type woofer and 1.75-inch high-frequency horn driver deliver total output power of up to 400 watts (LF: 300 watts, HF: 100 watts burst; 300 watts continuous total).
- Three balanced input connectors: XLR-3-31, XLR-3-32, and phone.
- Input level range is from -36 dB to +4 dB accepts output from your mixer as well as microphones, synthesizers, or other electronic musical instruments.
- Input level adjustment and a two-band equalizer.
- 35mm tripod stand mountable and 8-mm threaded holes facilitate wall or ceiling mounting.

MSR250

- New class D amplifier delivers 250 watts via a 10" cone woofer and 1" titanium-dome compression driver.
- Oversized 2.5" woofer voice coil with ferrofluid cooling for superior sonic performance and durability.
- Asymmetrical cabinet design plus acoustic insulation eliminates internal standing waves for pure, precise output.
- Dual inputs with independent EQ and level controls.
- Link out jack allows connection of multiple units for greater power and coverage.
- The ideal expansion speaker for the STAGEPAS 250M compact sound system.

OPTIONS

BCS251
Ceiling Bracket

BWS251-400
Wall Bracket

BBS251
Baton Bracket

MSR400

GENERAL SPECIFICATIONS

Type	Bi-amp 2-way, bass-reflex type powered speaker
Crossover frequency	1.6kHz
Frequency response	50Hz to 20kHz
Max. SPL	121dB (1m)
Dispersion	90(H) x 40(V)
Dimensions (W x H x D)	406 x 652 x 351mm (16.0" x 25.7" x 13.8")
Weight	23.0kg (50.7lbs)
Pole socket	35mm (1-3/8 inch) to 36mm

SPEAKER SECTION

Enclosure	Bass-reflex type
Components	LF: 12" cone + HF: 1.75" driver

AMPLIFIER SECTION

Output power	LF: 225W @ 500Hz, THD = 1%, RL = 4Ω HF: 75W @ 5kHz, THD = 1%, RL = 16Ω
Input sensitivity, impedance	MIC/LINE: -36dB/+4dB, 10kΩ
Connector (Input/Output) (all parallel)	1: XLR-3-31 balanced 2: XLR-3-32 balanced 3: PHONE balanced
Control	Level Control EQ, LOW (+/- 3dB at 55Hz) EQ, HIGH (+/- 3dB at HF) Power Switch (ON/OFF)
Indicator	Power: Green LED Clipping: Red LED
Power consumption	110W

DIMENSIONS

unit : mm

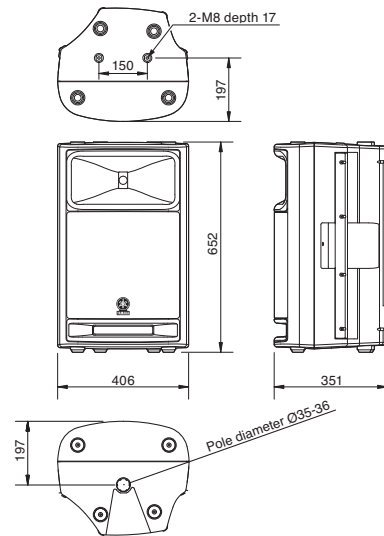

MSR250

GENERAL SPECIFICATIONS

Type	2-way powered speaker
Frequency response	-10dB: 50Hz to 20kHz
Nominal coverage	H: 90° V: 40°
Components	LF: 10" cone HF: 1" voice coil compression driver
Output power	200W
Maximum output level (1m; on axis)	116dB SPL
Processors	Equalizer (LOW: +/-13dB at 60Hz, HIGH: +/-6dB at 10kHz)
Line input and output connectors	INPUT 1: XLR-3-31 type/Phone jack(Balanced) INPUT 2/3: Phone jack/RCA pin(Unbalanced), LINK OUT: Phone jack
Power requirements	100V, 110V, 120V, 220V, 230V or 240V; 50/60Hz
Power consumption	40W
Dimensions (W x H x D)	342 x 544.5 x 298mm (13" x 21-1/2" x 11-3/4")
Weight	14.1kg (31-1/8lbs)
Flying and mounting hardware	2x M8-25
Pole socket	35mm (1-3/8 inch) to 36mm
Accessories	Owner's manual, AC cord

DIMENSIONS

unit : mm

