

Link



LK
connectors

Since the foundation in 1987, Link has focused on manufacturing and distributing a complete range of cables, connectors, and accessories dedicated to the entertainment industry.

Fascinated by the possibility of solving complex interconnection problems, our intent was to develop a team of specialists and a range of products specifically engineered to meet the demands of the market we serve.

Our idea has now grown into an organization dedicated to supplying customers with the highest quality products and services.

Link's team of distributors and manufacturers representatives enables us to offer tailor made support to our customers in all parts of the world.

MADE IN ITALY





Link



LK connectors

LKA Audio Multipin	2
Speaker Connectors	4
Multisignal Speaker	6
Hermaphrodite Connector	8
W Style Connectors	8
Coax Connectors	10
SCSI Connectors	10
LKH Head to Ballast	12
Power Link	14
LKS 19 Pin Connectors	16
LK Tools	18
Cable Reliefs	20
Dimensional Data	21
Standard Wiring	22
Terms of Sale	24

Ask for other catalogues
or visit our web sites

LKA Audio Multipin

Based on the MIL-C-5015 and VG 95234 standards, LKA connectors maintain the basic principle of strength and reliability of the military connectors. The restyling and construction of this range have been specifically studied to meet the needs of the entertainment industry. LKA configurations and their wiring standards, well established in the market, allow easy connection in all Live and PA Rental business applications.

LKA are available in male and female configurations in both cable and panel versions. The standard version features easy-grip long metal locking ring with internal roller coupling studs. The special retention of the protection dust cap was planned for military and railway applications. A full range of options featuring slim locking rings for easy coupling, long rubber locking rings, PCB versions, silver (from 13 to 85 pins) or gold (entire range) contacts, male and female connector dust caps, to satisfy the most demanding requirements. Also available on request a 19 pin configuration currently used for signal distribution by leading loudspeaker manufacturers as L-Acoustics.

For any different configuration requirement do not hesitate to contact us for a custom solution.



LK Series Standard cable connectors feature easy-grip long and slim metal locking rings, aluminium backshells and skin tops with anti-bending spring (from 13 to 54 pin versions) or standard skin tops (from 85 to 200 pin versions). **The studs** are roller version to ensure easier coupling and a larger number of operations due to a lower wear and tear of coupling ramps.

- 13 to 200 pins (4 to 66 channels)
- Easy and error-free mating
- Audible snap in quick bayonet lock
- Excellent resistance against unlocking
- Guaranteed for over 2000 coupling operations
- Waterproof up to 10 m (33 ft) for 12 hours
- Skin top cable clamp
- Highly resistant black finishing
- Roller studs for easier coupling
- High resistance to shock and vibrations



Reverse series
Locking ring on male connectors.
Available on request in all configurations.

LKP Series Rubber locking rings are available for inline connectors in all configurations.

STANDARD WIRING



Cable mounting

Male



LK 13 MV	13 poles
LK 25 MV	25 poles
LK 37 MV	37 poles
LK 54 MV	54 poles
LK 85 MV	85 poles
LK 150 MV	150 poles
LK 200 MV	200 poles

Panel mounting

Male



LK 13 MP	13 poles
LK 25 MP	25 poles
LK 37 MP	37 poles
LK 54 MP	54 poles
LK 85 MP	85 poles
LK 150 MP	150 poles
LK 200 MP	200 poles

Cable mounting with rubber locking ring

Female



LKP * FV	* poles		
LKP * FV **	* poles		
* = from 13 to 200 poles			
**			
B	R	G	Y
Blue	Red	Green	Yellow
Items subject to Minimum Order Qty			

Pins

Male



LK PMD	Gold for LK13-25-37-54-85
LK PMA	Silver for LK13-25-37-54-85
LK PMD R	Gold for LK 150
LK PMD RR	Gold for LK 200

Female



LK 13 FV	13 poles
LK 25 FV	25 poles
LK 37 FV	37 poles
LK 54 FV	54 poles
LK 85 FV	85 poles
LK 150 FV	150 poles
LK 200 FV	200 poles

Female



LK 13 FP	13 poles
LK 25 FP	25 poles
LK 37 FP	37 poles
LK 54 FP	54 poles
LK 85 FP	85 poles
LK 150 FP	150 poles
LK 200 FP	200 poles

LKA Connectors for PCB



LKI 25 FPS	25 poles
LKI 25 MPS	25 poles
LKI 37 MPS	37 poles
LKI 54 MPS	54 poles
LKI 85 MPS	85 poles
LKI 150 MPS	150 poles

Female



LK PFD T	Gold for LK13-25-37-54-85
LK PFA T	Silver for LK13-25-37-54-85
LK PFD R T	Gold for LK 150
LK PFD RR	Gold for LK 200

T= Tulipan version

Accessories

Dust cap



For connectors without locking ring

LK 20 TPM	For LK 13
LK 24 TPM	For LK 25
LK 28 TPM	For LK 37
LK 32 TPM	For LK 54
LK 40 TPM	For LK 85-150-200

Dust cap



For connectors with locking ring

LK 20 TPF	For LK 13
LK 24 TPF	For LK 25
LK 28 TPF	For LK 37
LK 32 TPF	For LK 54
LK 40 TPF	For LK 85-150-200

Rubber locking ring



LK 20 RL*	For LK 13
LK 24 RL*	For LK 25
LK 28 RL*	For LK 37
LK 32 RL*	For LK 54
LK 40 RL*	For LK 85-150-200

B	R	G	Y
Blue	Red	Green	Yellow
Items subjected to Minimum Order Qty			

● male pin
○ female pin

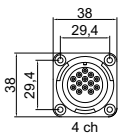

size 20
13 pins size 16

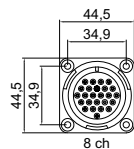

size 24
25 pins size 16

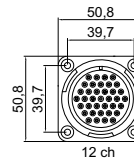

size 28
37 pins size 16

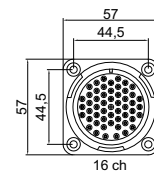

size 32
54 pins size 16

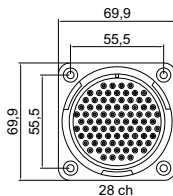

size 40
85 pins size 16

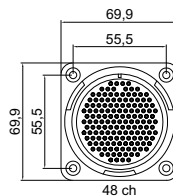

size 40
150 pins size 18

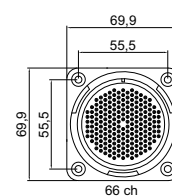

size 40
200 pins size 20

Speaker Connectors

Featuring 8 pins version (4 pins upon request) these connectors are currently used by leading loudspeaker manufacturers. Fully intermateable with CA-COM style connectors, they are becoming increasingly popular in the market due to their robust construction ideal for touring applications.

Link has also developed a standard speaker connector based on the Socapex style, featuring 16 pins, following indications from some of the largest international rental companies. This configuration enables to have a sufficient number of contacts for this application, avoiding the risk of incorrect interconnections with lighting connectors and to preserve the possibility to utilize the various models available in the standard LKS 19 pin range, like connectors with rubber locking ring in various colors (usually red), with set screw, long backshell etc. The standard LKS 19 pin connector is also available (Socapex style), as utilized by D&B.



Rubber locking ring available on both bayonet style and screw coupling connectors



4 pins speaker connectors available on request.

LKI 08

- 8 pins (4 on request)
- Easy and error-free mating
- Audible snap in quick bayonet lock
- Excellent resistance against unlocking
- Guaranteed for over 2000 coupling operations
- Waterproof up to 10 m (33 ft) for 12 hours
- Skin top cable clamp
- Highly resistant black finishing
- Roller studs for easier coupling
- High resistance to shock and vibrations

LKA 16

- 16 to 19 pins
- Screw coupling connectors
- Silk screen identification
- Excellent resistance against unlocking
- Guaranteed for over 2000 coupling operations
- Waterproof up to 10 m (33 ft) for 12 hours
- PG29 and PG36 cable relief or spider version
- Longer backshell version available (see pag 16-17)
- Set screw backshell available (see pag 16-17)
- Anodized version available (see pag 16-17)



Cable mounting



Male
LKI 08 MVD 8 poles w/pins

Female reverse
LK 08R FVD 8 poles w/pins

Panel mounting



Male
LKI 08 MPD 8 poles w/pins

Male reverse



Female
LKI 08R MPD 8 poles w/pins

Cable mounting with locking ring



Male reverse
LKI 08R MVD 8 poles w/pins

Female
LKI 08 FVD 8 poles w/pins

Cable mounting with rubber locking ring



Male reverse
LKI 08R MVPD 8 poles w/pins

Female
LKI 08 FVPD 8 poles w/pins

Female reverse
LKI 08 FPD 8 poles w/pins



Female reverse
LKI 08R FPD 8 poles w/pins

Cable mounting



Male
LKA D LM* PA M29 B1 16 p w/pins

LKA D LM* PA M36 B2 16 p w/pins
* = C: crimp - S: solder

Panel mounting



Male
LKA D PM* PA B 16 p w/pins

* = C: crimp - S: solder

Female



LKA D LF* M29 B1 16 p w/pins

LKA D LF* M36 B2 16 p w/pins
* = C: crimp - S: solder

Female



LKA D PF* B 16 p w/pins

* = C: crimp - S: solder

Cable mounting with rubber locking ring



Male
LKA D LM* RA M29 B1 16 p w/pins

LKA D LM* RA M36 B2 16 p w/pins
* = C: crimp - S: solder

Panel mounting with rubber locking ring



Male
LKA D PM* RA B 16 p w/pins

* = C: crimp - S: solder

Accessories

Dust caps



For connectors:
LK 22 TPM w/o locking ring
LK 22 TPF w/ locking ring

Rubber locking ring



LK 22 RL* For LKI 08

B	R	G	Y
Blue	Red	Green	Yellow

 Items subjected to Minimum Order Qty

Dust caps



For connectors:
LK 19 TPM w/ locking ring
LK 19 TPF w/o locking ring

Rubber locking ring



CLRRL32* For LKA 16

B	R	G	Y
Blue	Red	Green	Yellow

 Items subjected to Minimum Order Qty

● male pin
○ female pin

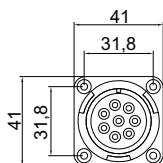

LKI 08
size 22
8 pins size 12

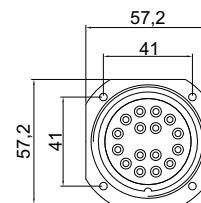

LKA 16
16 pins size 12

Multisignal Speaker

Thanks to the continuous direct line with its customers and the great flexibility in autonomously manufacturing cables and connectors, custom boxes and panels, which have long distinguished Link as a unique player in the sector, the company's challenge in recent years has been the creation of solutions for the distribution of different types of signals to satisfy those specific needs which new equipment or customer applications require. With regards to speaker array connections, two particular connectors and cables have been developed to satisfy the needs of new equipment requiring the connection of an increasing number of different types of channels in one sole connector mating.

LKA 24/6 utilized with **eurocable** SPKAL 12/3 U2A2 can convey power (3x4 mm²), 2 AES/EBU audio channels and 2 CAT6 ethernet in one sole connection, and has been purposely manufactured for the transport of all necessary signals to the JBL Self Powered Line Array.

LKA 48/6 was designed to connect the speaker clusters utilizing the least possible number of cables, precisely one sole 24 speaker lines cable for a total of 48 single-pole cables each with a 4 mm² section. Additionally, there was a need to have 2 AES/EBU channels for laser pointing and inclinometer control. LKA 48/6 features a mesh cable gland as standard.



- Easy and error-free mating
- Audible snap in quick bayonet lock
- Excellent resistance against unlocking
- Guaranteed for over 2000 coupling
- Waterproof up to 10 m (33 ft) for 12 hours
- Skin top (24/6) and mesh cable gland (48/6)
- Highly resistant black finishing
- Roller studs for easier coupling
- High resistance to shock and vibrations



CUS LKSPKAL 12/3 U2A2 with 24/6 connector can convey all necessary signals to the JBL Self Powered Line Array.

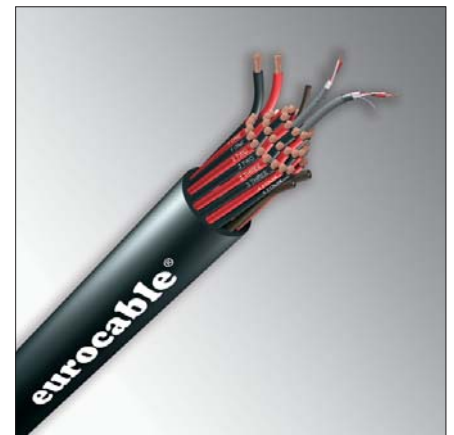

CUS LK48N40AD2 with 48/6 connector allows the connection of the speaker clusters utilizing the least possible number of cables.

STANDARD WIRING

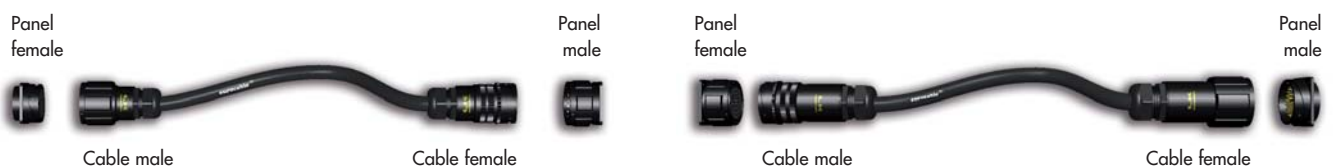

Cable mounting

Male



LKA 24/6R MV 30 poles w/pins

Panel mounting

Male



LKA 24/6R MP 30 poles w/pins

Cable mounting

Male



LKA 48/6 MV 54 poles w/pins
LKA 48/6 MV K plus kellems

Panel mounting

Male



LKA 48/6 MP 54 poles w/pins

Female



LKA 24/6R FV 30 poles w/pins

Female



LKA 24/6R FP 30 poles w/pins

Female



LKA 48/6 FV 54 poles w/pins
LKA 48/6 FV K plus kellems

Female



LKA 48/6 FP 54 poles w/pins

Cable mounting with rubber locking ring

Male



LKA 24/6R P MV 30 poles w/pins

Cable mounting with rubber locking ring

Female



LKA 48/6 P FV 54 poles w/pins
LKA 48/6 P FV K plus kellems

Accessories

Dust caps



For connectors:
LK 32 TPM w/o locking ring
LK 32 TPF w/ locking ring

Rubber locking ring



LK 32 RL* For LKA 24/6

B	R	G	Y
Blue	Red	Green	Yellow

 Items subjected to Minimum Order Qty

Dust caps



For connectors:
LK 40 TPM w/o locking ring
LK 40 TPF w/ locking ring

Rubber locking ring



LK 40 RL* For LKA 48/6

B	R	G	Y
Blue	Red	Green	Yellow

 Items subjected to Minimum Order Qty

● male pin
○ female pin

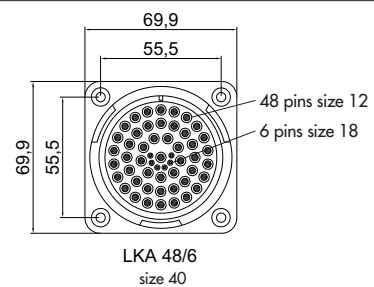
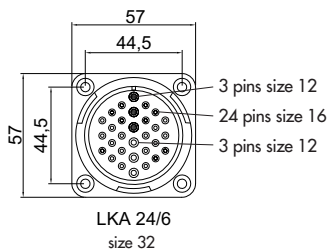

Hermaphrodite Connector

The LK M176 hermaphrodite connectors are utilized in the market to have only two versions of connectors, cable and panel. The range consists of a cable and panel version fully compatible with the traditional MASS series connectors widely used in the US professional audio market, often referred to as W4 connector. Dust caps are available for both models.

- 176 pins
- Screw coupling connectors
- Hermaphrodite insert
- Heavy duty machined metal shell
- IP 67 waterproof grade when mated
- Skin top or mesh cable gland
- Highly resistant black finishing



W Style Connectors

The LKW series connectors is based on the proven military, quick-disconnect MIL-26482 series. Featuring a three point quick mating bayonet coupling system and five insertion key polarisation they ensure a secure connection each time. Available in two contact configurations, 39 and 61 gold plated solder contacts fitted as standard.

- 39 or 61 pins
- Easy and error-free mating
- Audible snap in quick bayonet lock
- Excellent resistance against unlocking
- Guaranteed for over 2000 coupling operations
- Waterproof up to 10 m (33 ft) for 12 hours
- Skin top cable clamp
- Highly resistant black finishing
- Roller studs for easier coupling
- High resistance to shock and vibrations



STANDARD WIRING



Panel mounting



LKI M176 PS w/pins

Cable mounting



LKI M176 VS w/pins

Accessories

Dust cap



LKI M176 TPP For panel connector

Dust cap



LKI M176 TPV For cable connector

W Style Connectors

Cable mounting

Male



LKW 39LM 39 p w/pins and skin top
LKW 39LM D plus dust cup
LKW 39LM DK plus kellems

Cable mounting

Female



LKW 39LF 39 p w/pins and skin top
LKW 39LF D plus dust cup
LKW 39LF DK plus kellems

Panel mounting

Male



LKW 39PM 39 p w/pins
LKW 39PM D plus dust cup

Panel mounting

Female



LKW 39PF 39 p w/pins
LKW 39PF D plus dust cup

Cable mounting

Male



LKW 61LM 61 p w/pins and skin top
LKW 61LM D plus dust cup
LKW 61LM DK plus kellems

Cable mounting

Female



LKW 61LF 61 p w/pins and skin top
LKW 61LF D plus dust cup
LKW 61LF DK plus kellems

Panel mounting

Male



LKW 61PM 61 p w/pins
LKW 61PM D plus dust cup

Panel mounting

Female



LKW 61PF 61 p w/pins
LKW 61PF D plus dust cup

Accessories

Dust cap



For connectors with locking ring
LKW MDC39 For LKW 39
LKW MDC61 For LKW 61

Dust cap



For connectors without locking ring
LKW FDC39 For LKW 39
LKW FDC61 For LKW 61

Mesh cable gland

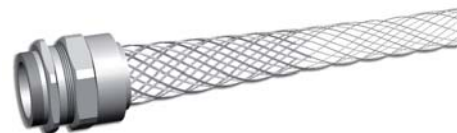

MCG PG2111 For LKW 39-61 (cable OD from 14.30 mm to 17.40 mm)
MCG PG2114 For LKW 39-61 (cable OD from 19.10 mm to 22.20 mm)

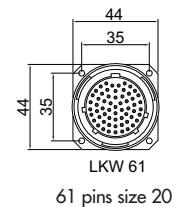
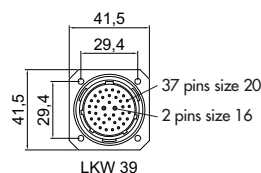
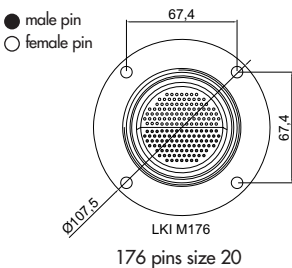

Coax Connectors

Three different arrangements to cover the vast range of requirements in the video sector which can support multiple coax signal transmission, AES/EBU and/or analog audio, ethernet, data, SCSI, etc..
LK Coax Connectors are available in male/female configurations both cable and panel versions to satisfy all connection requirements.

- High quality coax contacts (HDTV grade)
- Easy and error-free mating
- Audible snap in quick bayonet lock
- Excellent resistance against unlocking
- Guaranteed for over 2000 coupling operations
- Waterproof up to 10 m (33 ft) for 12 hours
- Skin top cable clamp
- Highly resistant black finishing
- Roller studs for easier coupling
- High resistance to shock and vibrations



LKA 40/89: 80 pins size 18 for signal transmission, 6 coaxial pins, 3 pins size 12 for power. To obtain improved performance they may be used with many **eurocable** hybrid cables.



LKA 40/58: 46 pins size 18 for signal transmission, 12 coaxial pins. To obtain improved performance they may be used with many **eurocable** hybrid cables.



LKA 40/18: 18 coaxial pins. To obtain improved performance they may be used with many **eurocable** hybrid cables.

SCSI Connectors

Replacing the fragile D-Sub 68 pins half pitch SCSI connector, a robust 72 pins LK bayonet conception model has been designed to offer high performance with greater reliability.

- 72 pins
- Easy and error-free mating
- Audible snap in quick bayonet lock
- Excellent resistance against unlocking
- Guaranteed for over 2000 coupling operations
- Waterproof up to 10 m (33 ft) for 12 hours
- Skin top cable clamp
- Highly resistant black finishing
- Roller studs for easier coupling
- High resistance to shock and vibrations



SCSI connectors: 72 pins size 20. To obtain improved performance they may be used with CVS LK YMHSCSI cable.

Cable mounting

Male



LKA 40/18 MV 18 poles w/pins
LKA 40/18 MV K plus kellems

Female



LKA 40/18 FV 18 poles w/pins
LKA 40/18 FV K plus kellems

Cable mounting with rubber locking ring

Female



LKA 40/18 P FV 18 poles w/pins
LKA 40/18 P FV K plus kellems

Panel mounting

Male



LKA 40/18 MP 18 poles w/pins

Female



LKA 40/18 FP 18 poles w/pins

Accessories

Dust cap



For connectors without locking ring
LK 40 TPM For coax connectors

Cable mounting

Male



LKA 40/58 MV 58 poles w/pins
LKA 40/58 MV K plus kellems

Female



LKA 40/58 FV 58 poles w/pins
LKA 40/58 FV K plus kellems

Cable mounting with rubber locking ring

Female



LKA 40/58 P FV 58 poles w/pins
LKA 40/58 P FV K plus kellems

Panel mounting

Male



LKA 40/58 MP 58 poles w/pins

Female



LKA 40/58 FP 58 poles w/pins

Dust cap



For connectors with locking ring
LK 40 TPF For coax connectors

Cable mounting

Male



LKA 40/89 MV 89 poles w/pins
LKA 40/89 MV K plus kellems

Female



LKA 40/89 FV 89 poles w/pins
LKA 40/89 FV K plus kellems

Cable mounting with rubber locking ring

Female



LKA 40/89 P FV 89 poles w/pins
LKA 40/89 P FV K plus kellems

Panel mounting

Male



LKA 40/89 MP 89 poles w/pins

Female



LKA 40/89 FP 89 poles w/pins

Rubber locking ring



LK 40 RL* For Coax connectors

B	R	G	Y
Blue	Red	Green	Yellow

 Items subjected to Minimum Order Qty

Cable mounting

Male



LK2324702 72 poles w/pins

Female



LK2324602 72 poles w/pins

Cable mounting with rubber locking ring

Male



LK2324703 72 poles w/pins

Panel mounting

Male



LK2324652 72 poles w/pins

Female



LK2324502 72 poles w/pins

Dust caps



For connectors:
LK 28 TPM w/o locking ring
LK 28 TPF w/ locking ring

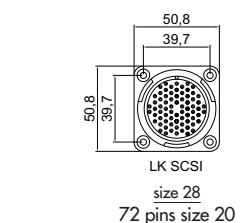
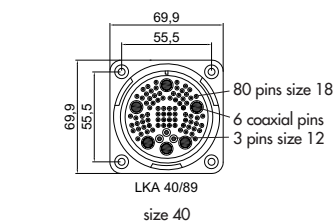
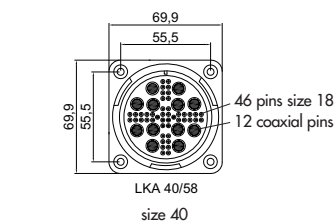
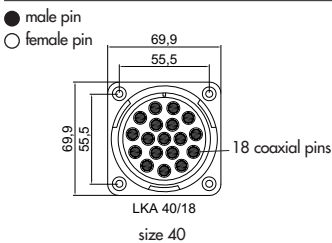

LKH Head To Ballast Connectors

The LKH range is the head-to-ballast interconnection solution. Covering the range from 400 W to 20 kW used by the lighting industry, LKH connectors incorporate features which ensure high quality, extreme durability and safe connections between ballast and lamps. The comprehensive range of available versions, including color code identification, along with its accessories make LKH connectors suitable for all possible applications. The coupling mechanism, the area most affected by wear and tear, features a thick machined construction and utilizes roller studs to allow easy coupling.

- Machined alloy and long locking rings
- Front and rear panel mounting available
- Roller studs coupling pins
- Machined backshells
- IP 67 waterproof grade when mated
- First In Last Out ground contacts
- Shell grounding
- Silver plated solder or crimp style contacts
- Suitable to fit various cable overall diameter



Example

Photo	Item
A	LKH 26-24-2-PSSW-00PG
B	LKH 01-24-2-SSSO-P21PG
C	LKH 06-24-11-PSSO-P21BG
D	LKH 02-24-11-SSSO-00PG

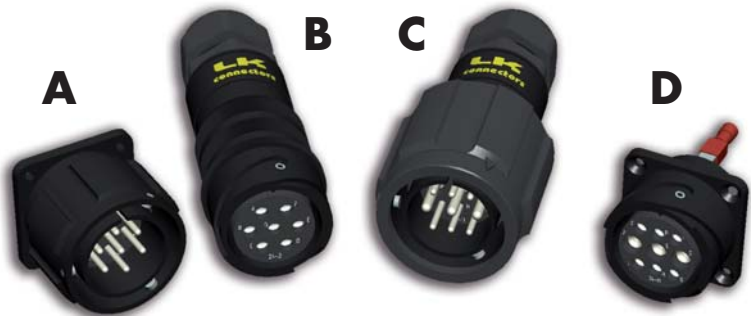

- male pin
- female pin

More arrangements available, please contact us for other configurations

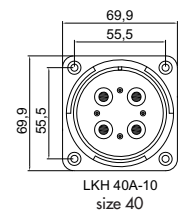
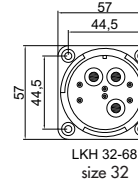
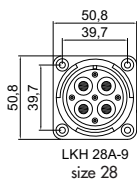
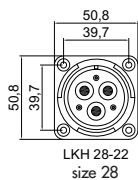
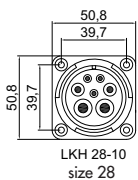
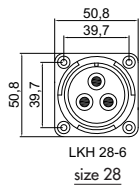
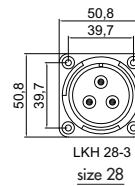
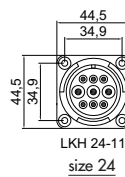
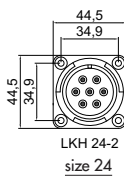
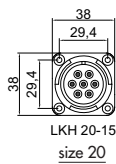
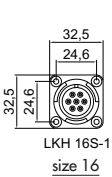

LKH Connectors ordering code

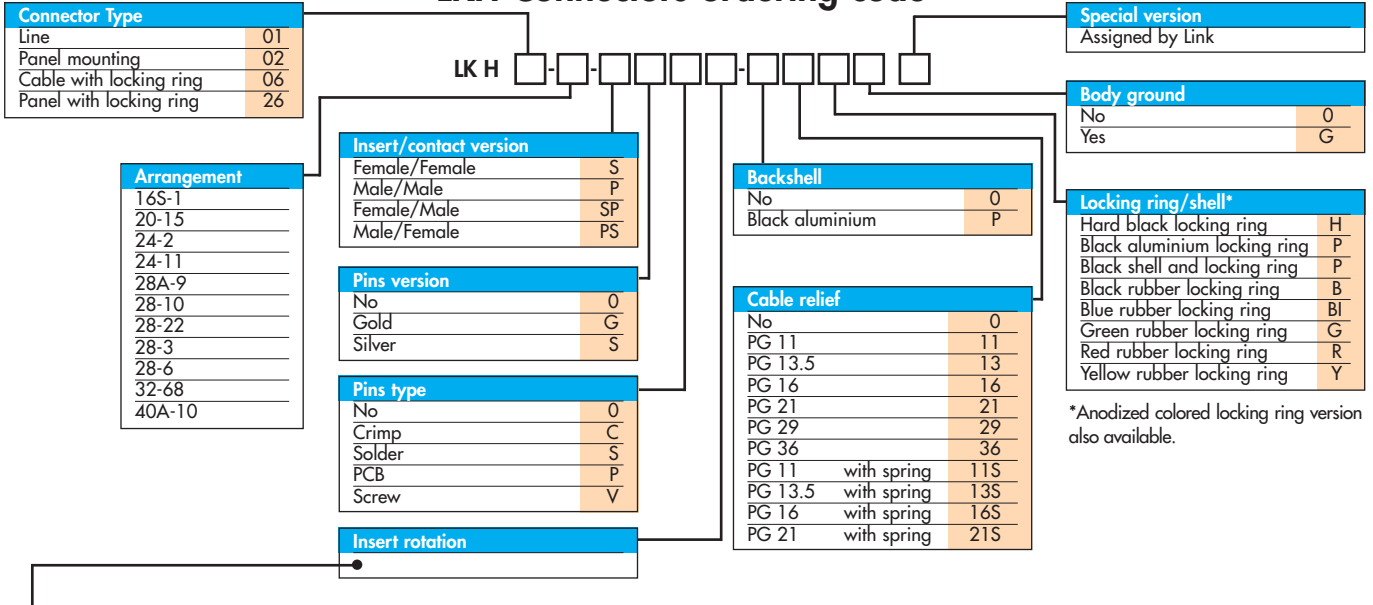

Insert rotation	Insert rotation degrees										
	Arrangement										
	16S-1	20-15	24-2	24-11	28-3	28-6	28A-9	28-10	28-22	32-68	40A-10
W	80	80	80	35	70	70	110	80	70	65	65
X	-	-	-	110	145	145	250	110	145	135	125
Y	-	-	-	250	215	215	260	250	215	225	225
Z	280	280	280	325	290	290	280	280	290	275	310

LKH Contacts ordering code

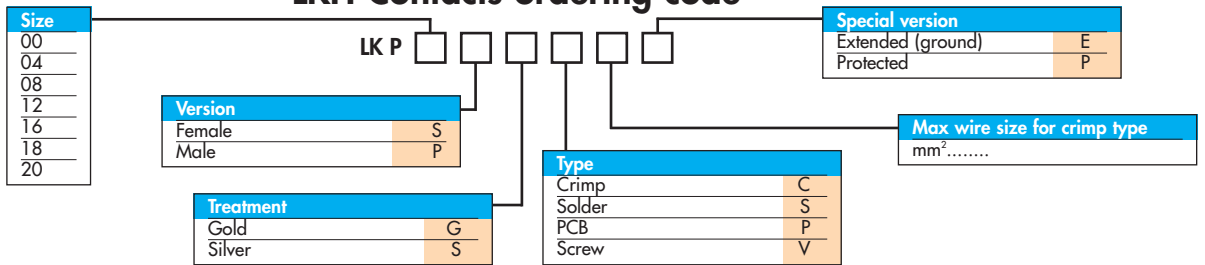

Pins size	Type and quantity of contacts by connector										
	Arrangement										
	16S-1	20-15	24-2	24-11	28-3	28-6	28A-9	28-10	28-22	32-68	40A-10
4						3	4	2	3	3	4
8				3	3			2			
12		7	7	6				3			
16	7						5		3	6	4
Total	7	7	7	9	3	3	9	7	6	9	8

	Arrangement by manufacturer								
	Arri	De Sisti	Strand	CMC	Mole	Lee	LTM	Sunray	
575	24-2W	24-2Z	24-2Z	24-2Z	24-2Z	16S-1	20-15	24-2Z	
1.200	24-2W	24-2W	24-2W	24-2W	24-2W	20-15	20-15	24-2W	
2.500	24-2	24-2	24-2	24-2	24-2	20-15	24-2	24-2	
4.000	24-2	24-11	24-11	24-11	24-2	24-11X	24-11	24-11	
6.000	28-22 (2)	32-68	32-68	32-68	28A-9 (1)	24-11	28A-9 (1)	28A-9 (1)	
12.000	28A-9 (2)	32-68	40A-10	28-10	40A-10	24-11	28A-9 (2)	28-10	
18.000	28A-9 (2)	32-68	40A-10	28-10	40A-10	24-11	28A-9 (2)	28-10	

(1) Male pins on connector with locking ring · (2) Female pins on connector with locking ring

Accessories

Dust caps



For male and female connectors

Rubber locking ring



B Blue **R** Red **G** Green **Y** Yellow

Items subjected to Minimum Order Qty

Shell contact



See connectors ordering code table
Body Ground

Ground pin



See contacts ordering code table
Special Version

Power Link

The Power Link single pole connector series is designed for power distribution systems, offering the ultimate features in safety and reliability under the most severe operating conditions. Typical applications for Power Link include three-phase motors, generators, load banks and lighting distribution panels. Power Link connectors are also suitable for utility companies and heavy industry environments. Power Link connectors are designed and tested to comply with European and US electrical safety standards and specifications. They are available in 400 A and 660 A versions.

- **Secondary locking:** to prevent accidental disconnection
- **Dead front contacts:** insulated nylon tip on the live contact prevents accidental handling.
- **High impact insulators:** glass filled nylon insulators prevent damage due to mishandling and guarantee a high degree of insulation, with maximum resistance to oil, fuel, acids and water.
- **Multipoint contact:** 23 sprung contact element grants a minimum insertion force and guarantees multiple points of contact, ensuring minimal power loss.
- **Integral location keys:** each connector type is individually keyed to eliminate the possibility of accidental cross mating.
- **Color coded:** insulators are supplied as with standard color identification codes.
- **Waterproof:** IP 67 rated sealing when mated.



The Power Link connector series has permanent integral keys which prevent the accidental connection of dissimilar types (e.g. Earth and line 1). Each connector type has a unique keyed position. Visual identifications are easily made by means of the color insulators.

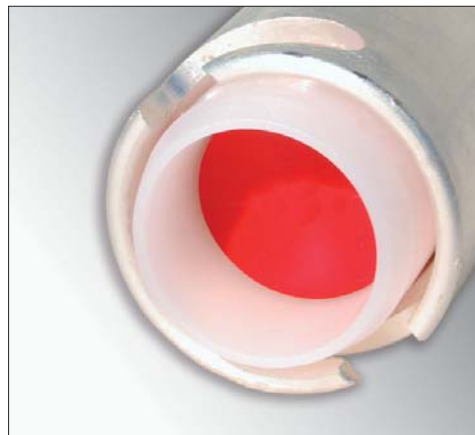

The sole locking system featuring the connection of the protected contact purely on metal parts



The drain protected connector features a patented double protection to prevent accidental touch of the drain contact under load. The drain contact must be unlocked supplying uniform pressure on the entire Teflon part (by means of the female connector).

The secondary locking pin can be unlocked through the Pin Key using only one hand.



STANDARD WIRING

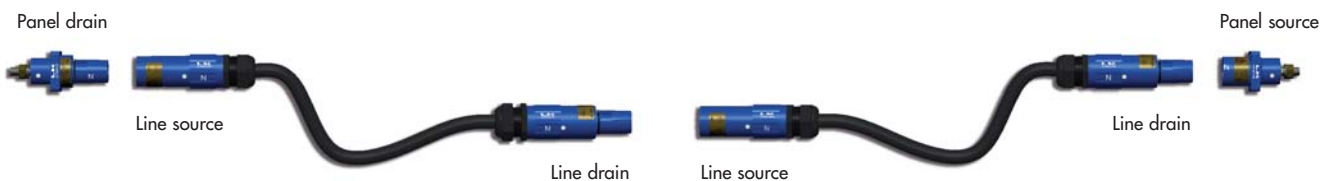



POWER Link



Technical data

Max Current Rating	400 A	660 A
Minimum Flashover	9.5 kV dc or ac	9.5 kV dc or ac
Maximum Rated Voltage to Earth	2 kV ac/3kV dc	2 kV ac/3kV dc
Operating Voltage	600 Vac	600 Vac
Operating Temperature	-30 to 125 C°	-30 to 125 C°
Insulation Resistance	>5 M Ω/500 Vdc	>5 M Ω/500 Vdc
AWG/mm ²	2-4/0 33.6-107.2	6/0 170.3
Threaded M 12 Torque Maximum	12.0 Nm	12.0 Nm
IP Rating (mated condition)	IP 67	IP 67
Operating Cycles	500 minimum	500 minimum

	GROUND KEY 1	NEUTRAL KEY 2	LINE 1 KEY 3	LINE 2 KEY 4	LINE 3 KEY 5
EUROPE HD 308 S2	GN	BL	BN	BK	GR
U.S.A.	GN	W	BK	R	BL

How to order Connectors

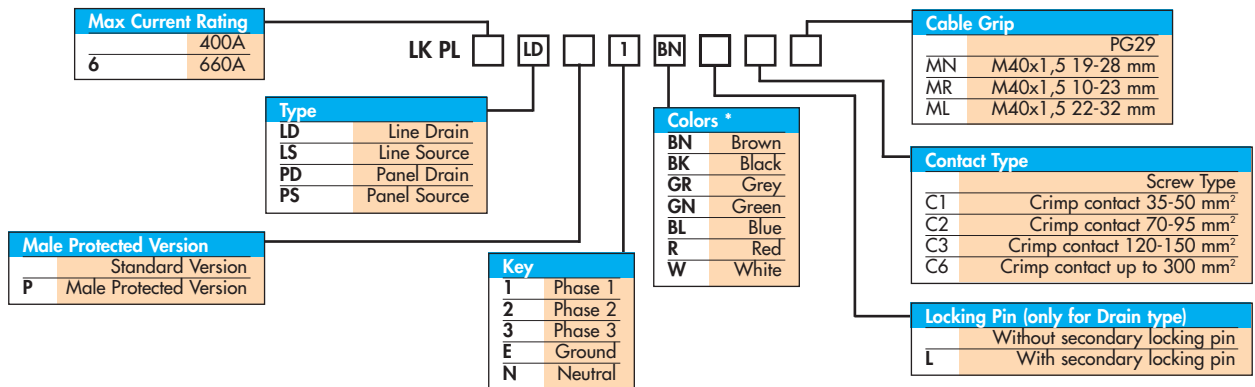

Accessories

Pin Key



LK PL KEY

Pin Key

Dust caps

Only available for EU HD 308 S2 version



LK PL TPD* Drain
LK PL TPS* Source

1BN 2BK 3GR EGN NBL
Brown Black Grey Green Blue

Spare parts



LK PL LOCK
Drive pin

LK PL R*
Compression sleeve
*35 (35 mm²)
*50 (50 mm²)
*70 (70 mm²)
*95 (95 mm²)
*120 (120 mm²)

LKS 19 Pin

The LKS connectors range has been specifically designed for professional lighting applications. While maintaining full compatibility with Socapex SL 419 series, LKS connectors represent a real breakthrough in terms of reliability and safety. Featuring machined contacts, they accept conductors from 1.5 to 4 mm². The neoprene insert guarantees greater reliability as well as the possibility to insert and eject contacts for crimping and maintenance. Also available with rubber locking ring and with hardened anodized finish that guarantees greater scratch resistance. The backshell design allows adequate working room for crimping operations. LKS is provided with IP 67 water-tight cable clamp.

- Screw coupling connector
- Ground first connection
- Tulip or retention spring pin
- Dual ground rings
- Plastic insulating sleeve
- Body ground fulfilling UL & NEC requirement
- Standard version: IP 67 waterproof
- Gold plated solder or crimp style contacts
- PG29, PG36, PG42, M40 and spider versions
- Long back shell and integrated locking set screw upon request
- Rubber coated locking rings (also in colored versions)

UL-CSA

The highest UL-CSA Rating obtained with a rubber insert:

UL Recognized for 25 A of continuous current (20A CNR)

The exclusive rubber silk-screened insert provides for easy and secure pin insertion while maintaining the highest continuous current ratings. The gold plated contacts with retaining spring pins ensure reliable mating every time.



LKS 19 Pin Splitter

A tough rubber moulding with incoming LKS 19 pin male connector and two outgoing LKS 19 pin female connectors.

LKS 19 Pin Spider Connector

The LKS 19 pin spider connector utilized for break-ins and break-outs is the only available connector which maintains the width of the PG29 configurations and guarantees secure fan out terminations with a highly resistant strain relief. IP 64 rated, this version features long back shell and integrated locking set screw as standard features.

STANDARD WIRING





LKS Ordering code

LKS	D	LMS	PA	M29	B	1
-----	---	-----	----	-----	---	---

Version	
Die cast aluminium	D
Machined aluminium	M

Connector Type	
Cable male solder	LMS
Cable male crimp	LMC
Cable female solder retention tulip	LFSR
Cable female solder tulip	LFST
Cable female crimp retention tulip	LFCR
Cable female crimp tulip	LFCT
Panel male solder	PMS
Panel male crimp	PMC
Panel female solder retention tulip	PFSR
Panel female solder tulip	PFST
Panel female crimp retention tulip	PFCR
Panel female crimp tulip	PFCT

Locking ring material	
Aluminium black painted	PA
Aluminium black rubberized	RA
Aluminium colored rubberized	R**
Aluminium black anodized	A
Aluminium colored anodized	*
Without ring	blank space

**	B	R	G	Y	GR
	Blue	Red	Green	Yellow	Grey

Items subjected to Minimum Order Qty

Cable relief	
Plastic PG29	1
Plastic PG36	2
Plastic PG42	3
Aluminium (silver) w/stainless mesh PG29	4S
Aluminium (silver) w/stainless mesh PG36	5S
Rubber six way x 1,5 mm ² cable	S1
Rubber six way x 2,5 mm ² cable	S2
Plastic M40x1,5	6
Plastic M40x1,5 R	6R

Shell & Backshell color	
Black painted	B
Black anodized	A
Colored anodized	A*

Backshell version	
Aluminium PG29	M29
Aluminium PG36	M36
Aluminium PG42	M42
Aluminium long vers. PG29	L29
Aluminium long vers. PG36	L36
Aluminium for six way cable relief	MS
Aluminium metric thread M40	M40
Set Screw version: add	X

*	B	R	G	Y	S
	Blue	Red	Green	Gold	Silver

Items subjected to Minimum Order Qty

Tulip Pins

The conventional 4 blade tulip style pin provides the ample contact surface area for maximum conduction.



Retention Spring Pins

The enhanced spring pin provides the maximum surface area of a conventional tulip pin with the added benefit of a stainless steel spring clip. This combination, only available from LK Connectors, enables the tulip to provide tighter retention and improves reliability over the life of the connector.



Serviceable Plastic Insulating Sleeve

Easily installed or removed once terminations are completed. They provide a dependable insulator between the connector housing and internal conductors.



Durable Backshell

Available in two lengths for ultimate serviceability.



The anodized aluminium version is available in multiple colors (see color table above).

Accessories

Dust cap



For connectors:
LKS 19 TPM w/ locking ring

Dust cap



For connectors:
LKS 19 TPF w/o locking ring

Rubber locking ring



CLRLRL32* For LKS
* **B** **R** **G** **Y** **GR**
Blue Red Green Yellow Grey
Items subjected to Minimum Order Qty

Robust strain relief



PG29 and PG36 configurations, with two size Spider grips for fan in/out. Optional PG42, M40 or mesh cable gland are also available.

- male pin
- female pin

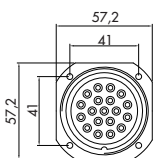

LKS 19
19 pins size 12

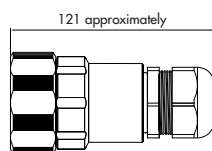

LKS with PG29 backshell

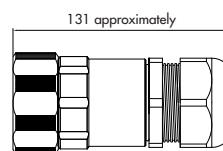

LKS with PG36 backshell

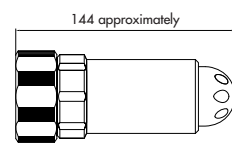

LKS 19 Spider

LK Tools

LK CRIMP

The crimp contact option for the LKA, LKS and LKH range of connectors, allows large assembly time savings, and gives a perfect, reliable and durable connection with the use of LK CRIMP or LK CRIMP PN with Turret tools (LK TR).

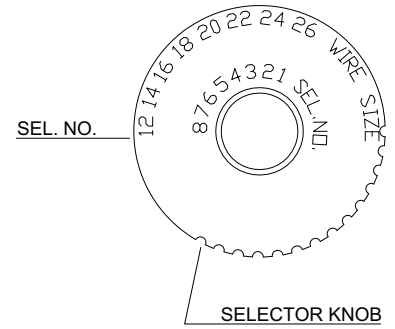

LK CRIMP LK CRIMP PN

Crimping tool for LKA-LKS-LKH
Pneumatic crimping tool for LKA-LKS-LKH

POSITIONER

Every pin size has its own positioner (LK PS..), to be mounted on the universal turret LK TR. The mounting position is selected following the female or male contact type.



LK SP 12 LK SP 18
LK SP LKS LK SP 16

LK PS LKS	Positioner for LKS pins
LK PS 12	Positioner for pins size 12 LKH
LK PS 16	Positioner for pins size 16 LKA 13-85
LK PS 18	Positioner for pins size 18 LK 150
LK PS 20	Positioner for pins size 20 LK 200

INSERTER

The insertion of contacts is made by the inserter LK INS (12, 16, 18 or 20 following the contact size). For easier contact insertion use an alcohol lubricant.



LK INS12	Inserter for pin size 12 (LKS - LKH)
LK INS16	Inserter for pin size 16 (LK 13-85 poles)
LK INS18	Inserter for pin size 18-20 (LK 150-200 poles)

TURRET

The turret, fitted on the LK CRIMP, allows the positioner's assembly.



LK TR Turret

SELECTOR KNOB POSITIONS

Contact Size	AWG 26	AWG 24	AWG 16	AWG 14	AWG 12	Wire Size
20	1	2				Sel No.
18	1	2				
16	1	2				
12			6	7	8	

A few examples of the most popular combinations of contact/wire sizes

DRIVE PIN

Female contacts may be inserted with the aid of the plug LK SP (12, 12 LKS, 16, 18 or 20) as shown in the drawing.



LK SP LKS	Drive pin for LKS
LK SP12	Drive pin size 12 for LKH
LK SP16	Drive pin size 16 for LK 13-85 poles
LK SP18	Drive pin size 18 for LK 150 poles
LK SP20	Drive pin size 20 for LK 200 poles



DUMMY

Dummy range is available for the assembly of the LK connector back shells. Dummy tools can be fixed to a panel or gripped in a vice: lock the back shell in place by means of the LK K BK key. Once the LK K has been fixed to the panel or to the vice, place the connector for assembly in the mating position. Next, screw the back shell firmly into place with the LK K BK key. This allows to screw the backshell at best, avoiding unscrewing during operations.



LK K 20	Dummy for size 20 (13 poles)
LK K 20LR	Dummy for size 20 (13 poles with locking ring)
LK K 24	Dummy for size 24 (25 poles)
LK K 24LR	Dummy for size 24 (25 poles with locking ring)
LK K 28	Dummy for size 28 (37 poles)
LK K 28LR	Dummy for size 28 (37 poles with locking ring)
LK K 32	Dummy for size 32 (54 poles)
LK K 32LR	Dummy for size 32 (54 poles with locking ring)
LK K 40	Dummy for size 40 (85/150/200 poles)
LK K 40LR	Dummy for size 40 (85/150/200 poles with locking ring)

LK K BK KEY



LK K BK Tool to tighten

Recommended Tightening Torque

Shell Size	Shell/Backshell	
	Coupling Torque Maximum (Nm)	Uncoupling Torque Minimum (Nm)
16S	2.71	0.45
18	3.16	0.56
20	3.61	0.68
22	4.06	0.78
24	4.96	0.78
28	5.88	0.90
32	7.35	1.01
40	8.34	1.47

PG & METRIC THREAD	Torque Backshell/Clamp (Nm)	Torque for cap nut (Nm)
PG11	3.75	2.5
PG13.5	3.75	2.5
PG 16	5.0	3.3
PG 21	7.5	5.0
PG 29	7.5	5.0
PG 36	7.5	5.0
PG 42	7.5	5.0
M40 X 1.5	13.0	13.0



LK EX

Pin

EJECTOR HANDLE

To extract the contacts the use of LK EX MNUNIV ejector is required; it contains the metal points suitable for the different sizes (LK EX..), both for female and male contacts.



LK EX MNUNIV Handle

The handle on which the ejector points are screwed on. This unit also contains them internally by opening the rear lid.

EJECTOR

The main contacts used in the LK range can be contained inside the LK EX MNUNIV and must be screwed into the front part of the Handle.



LK EX12F	Female size 12 LKS
LK EX12F R	Female size 12 LKH
LK EX12M	Male size 12 LKS
LK EX16F	Female size 16 for connector LK
LK EX16M	Male size 16 for connector LK
LK EX18F	Female size 18 for connector LK
LK EX18M	Male size 18 for connector LK
LK EX20F	Female size 20 for connector LK
LK EX20M	Male size 20 for connector LK

Cable Reliefs

SKIN TOP · Cable Clamp

The use of SKIN TOP cable clamps, which are important accessories in the industrial field, allows perfect connection of any cable to all types of equipment, ensuring perfect functioning. They are mostly used in the audio-lighting environment, as cable clamps for multipin connectors and cable entries in various types of boxes, e.g. stage-boxes. SKIN TOP cable clamps allow easy and quick installation. The new trapezoid-shaped multiple thread allows rapid tightening. The IP 68 watertight cable clamp is mounted on the tightening nut, ensuring a firm grip with no traction and no loosening risk.

Cable O.D.

PG11	From 5 to 10 mm
PG13,5	From 6 to 12 mm
PG16	From 10 to 14 mm
PG21	From 13 to 18 mm
PG29	From 18 to 25 mm



Skin Top with spring

Cable clamp with anti-bend spiral, range from PG 11 to PG 21. It provides additional safety to the cable preventing it to be curved over its bend radius. Black (RAL 9005). Water-tightness degree IP 68.

Metal Skin Top

Available on request, nickel-plated brass cable clamp for heavy-duty applications. With all the advantages of the Skin Top range. Water-tightness degree IP 68. Range from PG 11 to PG 36.

Skin Top

Code

Description

SK TOP PN13	PG11 for cables 5-10 mm
SK TOP PN19	PG13,5 for cables 6-12 mm
SK TOP PN35	PG16 for cables 10-14 mm
SK TOP PN54	PG21 for cables 13-18 mm
SK TOP PN85	PG29 for cables 18-25 mm
SK TOP PN150	PG36 for cables 22-32 mm

Skin Top with spring

Code

Description

SK TOP PM13	PG11 for cables 5-10 mm
SK TOP PM19	PG13,5 for cables 6-12 mm
SK TOP PM35	PG16 for cables 10-14 mm
SK TOP PM54	PG21 for cables 13-18 mm

Metal Skin Top

Code

Description

SK TOP MN13	PG11 for cables 5-10 mm
SK TOP MN19	PG13.5 for cables 6-12 mm
SK TOP MN35	PG16 for cables 10-14 mm
SK TOP MN54	PG21 for cables 13-18 mm
SK TOP MN85	PG29 for cables 18-25 mm
SK TOP MN150	PG36 for cables 22-32 mm

Metal nut

Code

Description

SK TOP MD13	For SK TOP MN 13
SK TOP MD19	For SK TOP MN 19
SK TOP MD35	For SK TOP MN 35
SK TOP MD54	For SK TOP MN 54
SK TOP MD85	For SK TOP MN 85
SK TOP MD150	For SK TOP MN 150



Plastic nut

Code

Description

SK TOP PD13	For SKINTOP PG11
SK TOP PD19	For SKINTOP PG36
SK TOP PD35	For SKINTOP PG13.5
SK TOP PD54	For SKINTOP PG16
SK TOP PD85	For SKINTOP PG21
SK TOP PD150	For SKINTOP PG29

When Skin tops are used for panel mount, a nut (plastic or metal) will be required



Mesh cable gland & grip

The MCG grips series features a patented swivel design that provides superior cable pull-out protection. This unique design virtually eliminates premature mesh fatigue thereby maximizing both cable and connection life so that downtime and costs are greatly reduced. This is the only swivel grip for extreme flexing applications that is specified by industry experts to meet their flexing requirements.

Mesh cable gland

Code

Description

MCG PG1108	Mesh cable gland PG11 - Cable OD from 11.10 mm to 12.70 mm
MCG PG1609	Mesh cable gland PG16 - Cable OD from 11.10 mm to 14.30 mm
MCG PG1611	Mesh cable gland PG16 - Cable OD from 14.30 mm to 17.40 mm
MCG PG2111	Mesh cable gland PG21 - Cable OD from 14.30 mm to 17.40 mm
MCG PG2114	Mesh cable gland PG21 - Cable OD from 19.10 mm to 22.20 mm
MCG PG2914	Mesh cable gland PG29 - Cable OD from 19.10 mm to 22.20 mm
MCG PG2916	Mesh cable gland PG29 - Cable OD from 22.20 mm to 25.40 mm
MCG PG2918	Mesh cable gland PG29 - Cable OD from 25.40 mm to 28.60 mm
MCG PG2920	Mesh cable gland PG29 - Cable OD from 28.60 mm to 31.80 mm
MCG PG3618	Mesh cable gland PG36 - Cable OD from 25.40 mm to 31.80 mm

Mesh cable grip

Code

Description

MCG SE013	Mesh cable grip - Cable OD from 12.70 mm to 13.20 mm
MCG SE014	Mesh cable grip - Cable OD from 16.00 mm to 18.80 mm
MCG SE015	Mesh cable grip - Cable OD from 19.10 mm to 22.90 mm
MCG SE016	Mesh cable grip - Cable OD from 25.40 mm to 31.50 mm
MCG SE017	Mesh cable grip - Cable OD from 31.80 mm to 37.80 mm

Dimensional Data

Cable Dimension to be used with PG or Metric Glands

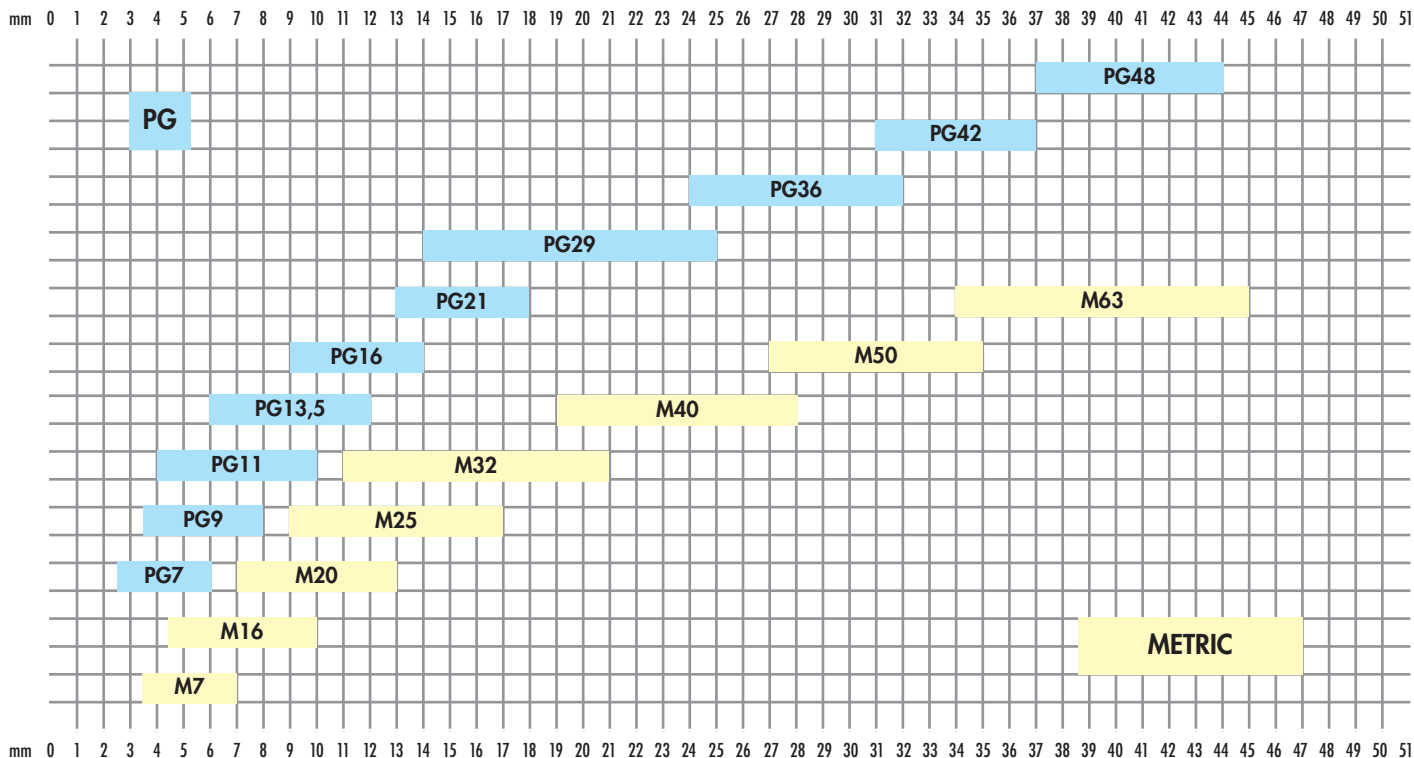

LKA Dimensional Data

Size	No. Pins	L1 mm	L2 mm	L2 mm 03 Rear mount.	L3 mm	L4 mm	L5 mm	D1 mm	D2 mm	D3 mm
20	13	34.2	19.0	23	4	38.0	29.4	34.2	28.5	3.2
24	25	36.0	20.6	23	4	44.5	34.9	40.9	35.3	3.7
28	37	36.2	20.6	24	4	50.8	39.7	46.7	41.4	3.7
32	54	37.6	22.2	24	4	57.0	44.5	53.4	47.8	4.3
40	85 150/200	37.6	22.2	24	4	69.9	55.5	65.5	59.0	4.3

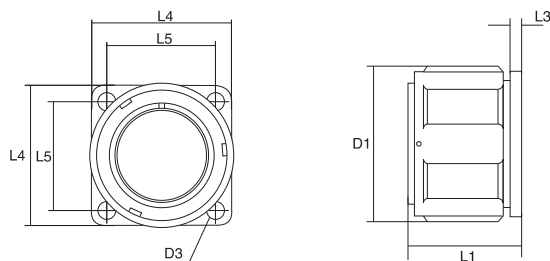
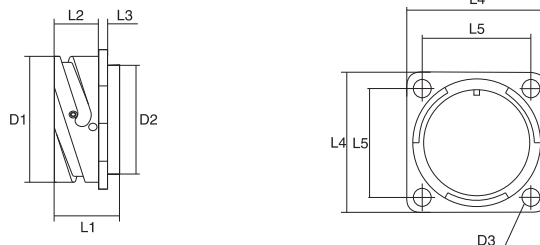

Size	No. Poli LKA	L1 mm	L3 mm	L4 mm	L5 mm	D1 mm	D3 mm
20	13	38.6	4	38.0	29.4	42.5	3.2
24	25	41.0	4	44.5	34.9	49.6	3.7
28	37	41.8	4	50.8	39.7	56.5	3.7
32	54	44.0	4	57.0	44.5	63.5	4.3
40	85 150/200	45.0	4	69.9	55.5	75.5	4.3

Pins

Contact Size	Max Current (Short time)	Rated and Test Current	Potential Drop Maximum
20	7.5 A	7.5 A	83 mV
18	10 A	7.5 A	83 mV
16	22 A	13 A	74 mV
12	41 A	23 A	63 mV
8	73 A	46 A	65 mV
4	135 A	80 A	58 mV
0	245 A	150 A	53 mV

Standard Wiring

4 ch - LK 13			
Ch	+	-	G
1	B	C	E
2	F	K	H
3	J	D	A
4	N	M	G
General ground			

8 ch - LK 25			
Ch	+	-	G
1	A	E	F
2	G	C	B
3	D	H	J
4	M	L	K
5	Q	P	N
6	W	S	R
7	T	X	Y
8	Z	V	U
General ground a			

12 ch - LK 37			
Ch	+	-	G
1	E	F	A
2	B	C	G
3	H	J	D
4	S	T	K
5	L	M	U
6	V	W	N
7	P	R	X
8	a	b	g
9	c	d	i
10	e	f	m
11	n	p	h
12	e	s	k
General ground z			

16 ch - LK 54			
Ch	+	-	G
1	W	f	r
2	J	R	a
3	k	v	AC
4	E	M	V
5	e	q	y
6	B	H	P
7	Z	j	u
8	D	L	U
9	d	p	x
10	A	G	O
11	Y	h	t
12	C	K	T
13	c	n	w
14	F	N	X
15	g	s	AB
16	S	b	m
General ground AG			

28 ch - LK 85			
Ch	+	-	G
1	A	B	C
2	E	F	H
3	J	K	L
4	N	P	R
5	S	T	U
6	X	Y	Z
7	a	b	c
8	d	f	g
9	h	i	j
10	k	m	n
11	p	q	r
12	t	u	v
13	w	x	y
14	z	AA	AB
15	AC	AD	AE
16	AF	AH	AJ
17	AK	AL	AM
18	AP	AR	AS
19	AT	AU	AV
20	AW	AX	AY
21	AZ	BA	BB
22	BC	BD	BE
23	BJ	BK	BL
24	BM	BN	BP
25	BS	BT	BU
26	BV	BR	BF
27	BH	AN	S
28	W	M	D
General ground V			

● male pin
○ female pin



4 ch - LK13

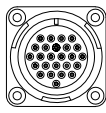

8 ch - LK25

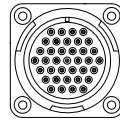

12 ch - LK37

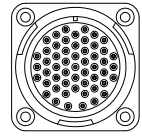

16 ch - LK54

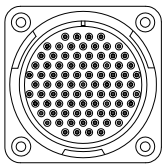

28 ch - LK85

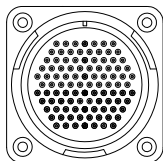

32 ch - LK100

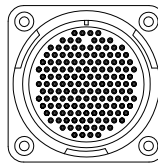

48 ch - LK150

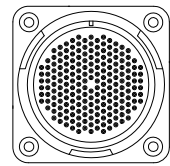

66 ch - LK200

32 ch - LK 100			
Ch	+	-	G
1	1	2	3
2	4	5	6
3	7	8	9
4	10	11	12
5	13	14	15
6	16	17	18
7	19	20	21
8	22	23	24
9	25	26	27
10	28	29	30
11	31	32	33
12	34	35	36
13	37	38	39
14	40	41	42
15	43	44	45
16	46	47	48
17	49	50	51
18	52	53	54
19	55	56	57
20	58	59	60
21	61	62	63
22	64	65	66
23	67	68	69
24	70	71	72
25	73	74	75
26	76	77	78
27	79	80	81
28	82	83	84
29	85	86	87
30	88	89	90
31	91	92	93
32	94	95	96
33	97	98	99

LKS - 6 Lamps			
Ch	Fase	Neutral	Ground
1	1	2	13
2	3	4	14
3	5	6	15
4	7	8	16
5	9	10	17
6	11	12	18
General ground		19	

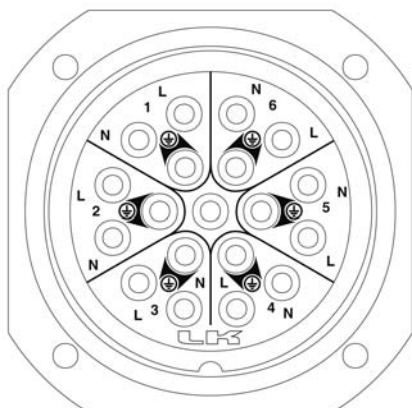

48 ch - LK 150			
Ch	+	-	G
1	1	2	3
2	5	6	7
3	8	9	10
4	11	12	13
5	14	15	16
6	17	18	19
7	21	22	23
8	24	25	26
9	27	28	29
10	20	30	31
11	32	33	34
12	35	36	37
13	38	39	40
14	41	42	43
15	44	45	46
16	47	48	49
17	50	51	52
18	53	54	55
19	57	58	59
20	60	61	62
21	63	64	65
22	66	67	68
23	69	70	71
24	72	73	74
25	75	76	77
26	78	79	80
27	82	83	84
28	85	86	87
29	88	89	90
30	91	92	93
31	94	95	96
32	97	98	99
33	100	101	102
34	103	104	105
35	56	81	106
36	107	108	109
37	110	111	112
38	113	114	115
39	116	117	118
40	119	120	121
41	122	123	124
42	125	126	127
43	139	128	129
44	130	131	132
45	133	134	135
46	136	137	138
47	140	141	142
48	143	144	145
General ground		150	

66 ch - LK 200			
Ch	+	-	G
1	A1	A2	A3
2	A4	A5	A6
3	B8	C10	C11
4	B7	B6	B5
5	B4	B3	B2
6	B1	C2	C1
7	C3	C4	C5
8	C7	C8	C9
9	D12	D11	D10
10	D9	D8	D7
11	D6	D5	D4
12	D3	D2	D1
13	F1	E1	E2
14	E3	E4	E5
15	E6	E7	E8
16	E9	E10	E11
17	E12	E13	F14
18	F13	F12	F11
19	F10	F9	F8
20	F7	F6	F5
21	F4	F3	F2
22	G1	G2	G3
23	G4	G5	G6
24	G7	G8	G9
25	G10	G11	G12
26	G13	G14	G15
27	H14	H13	H12
28	H11	H10	H9
29	H6	H5	H4
30	H3	H2	H1
31	L1	L2	L3
32	L4	L5	L6
33	H7	L7	M7
34	H8	L8	M8
35	L9	L10	L11
36	L12	L13	L14
37	M14	M13	M12
38	M11	M10	M9
39	M6	M5	M4
40	M3	M2	M1
41	N1	N2	N3
42	N4	N5	N6
43	N7	N8	N9
44	N10	N11	N12
45	N13	N14	N15
46	P13	P12	P11
47	P10	P9	P8
48	P7	P6	P5
49	P4	P3	P2
50	P1	R1	R2
51	R3	R4	R5
52	R6	R7	R8
53	R9	R10	R11
54	R12	R13	P14
55	S12	S11	S10
56	S9	S8	S7
57	S6	S5	S4
58	S3	S2	S1
59	T1	T2	U1
60	T3	T4	T5
61	T7	T8	T9
62	T11	T10	U8
63	U7	U6	U5
64	U4	U3	U2
65	V1	V2	V3
66	V4	V5	V6
General ground		T6	

Terms of Sale

PRICES

All prices are expressed in Euro (€), excluding V.A.T. and may be subject to change without any notice.

PAYMENT

All goods must be paid in advance by wire transfer. Any other payment terms must be previously agreed and allowed by LINK Srl.

ORDERS

Minimum order value is € 1.000. A written order must always be sent, either by email or by fax, as confirmation of telephone instructions. The contractual tie raised from the accomplishment of each single order is governed by the regulations of these conditions of sale. The buyer renounces to its own possible conditions of purchase, unless differently agreed upon and specifically accepted in writing by LINK Srl.

DELIVERY

Goods are normally dispatched within one week from confirmation of order. Nevertheless this delivery term is purely arbitrary as it may depend on both production times and circumstances beyond our control such as strikes, customs clearance and carriers. LINK Srl cannot therefore be responsible in any case and for any reason for any damage caused by delayed deliveries. The buyer is not authorized in any case to cancel the order, without prior written authorization, or to claim for any reimbursement of damages to any order or shipment whatsoever.

SHIPMENTS

All goods are shipped Ex-Works and travel at the buyer's risk. For this purpose, the buyer must indicate the means of transport chosen when placing the order. LINK Srl will not be responsible for any theft, loss or damage with regard to the carriage of goods. The buyer undertakes to verify the number of items and their integrity in debate with either its carrier or its forwarding agent. Any theft, loss or damage to the goods in transit must be notified and claimed to them upon receipt of goods. LINK Srl may offer transportation on the buyer's behalf at rates to be agreed upon prior to shipment. In the event of any theft, loss or damage in such cases, a note must be made in writing on the transport document upon delivery and to LINK Srl immediately, otherwise no reimbursement can be claimed by the buyer.

RETURN OF GOODS

No returned goods can be accepted without prior authorization by LINK Srl. Once authorized, as defective goods or not in conformity with the order, they will be returned to LINK Srl carriage free,

accompanied by a regular Return Bill detailing invoice numbers for each item returned, the products will be credited at the price applied at the time of purchase, less 10%. Goods accepted back as defective that should show marks of poor packing or improper use, will not be replaced but immediately returned to the buyer freight collect.

WARRANTY

The warranty is limited to the replacement of the products which are recognized as defective, except when directly or indirectly damaged, as per art. 1490 and subsequent amendments of the Italian Civil Code. The warranty does not include the normal perishability of goods nor the consequences of incorrect installation or breakage caused by improper use or lack of care. The products have to be perfectly installed attentively following the instructions of mounting/use. With this aim, the buyer exempts LINK Srl from any responsibility regarding improper use, non-observance of the safety regulations, technical specifications or instructions of use.

TECHNICAL SPECIFICATIONS

All products are liable to change without prior notice, in view of the manufacturing policy based on "continuous improvement" of the product quality.

OWNERSHIP

In case of total or partial invoice payment failure over the due term, the relative interests will be immediately charged to the buyer at the current rate as well as the additional bank commissions and fees. LINK Srl will be authorized to hold any further supply of goods in case of failure of payment due to any reason. The property of goods supplied by LINK Srl shall not pass to the buyer until the agreed price, including possible freight charges and taxes, are completely paid. In case of both total or partial payment failure, LINK Srl will immediately resume the ownership of the goods, leaving unprejudiced all other legal and contractual consequences of arrearage.

GENERAL CONDITIONS

The placing of orders to LINK Srl imply the knowledge and full acceptance of the above mentioned conditions of sale by the buyer. Any issue which is not mentioned in these Terms of Sale will be ruled by the current Italian law.

LEGAL CONSTRUCTION

All contracts concluded with LINK Srl shall be governed by the Italian law. LINK Srl elects the Court of Rome as governing Forum in case of controversies.



LINK srl

Via Pieve Torina, 46/48 - 00156 Rome (Italy)

tel. +39 06 227251 - Fax +39 06 22725225

www.linkitaly.com - info@linkitaly.com

LINK USA Inc

1020 Bunnell Road, Altamonte Springs, FL 32714, USA

tel +1 4077740088 - Fax +1 4074725064

www.linkusa-inc.com - info@linkusa-inc.com